

Pickit L facts

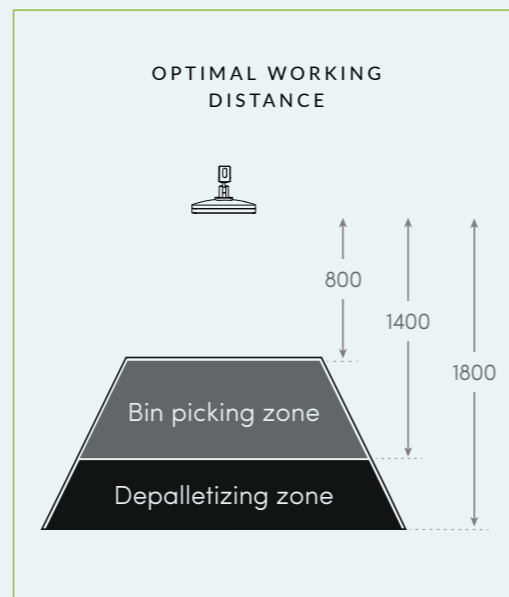
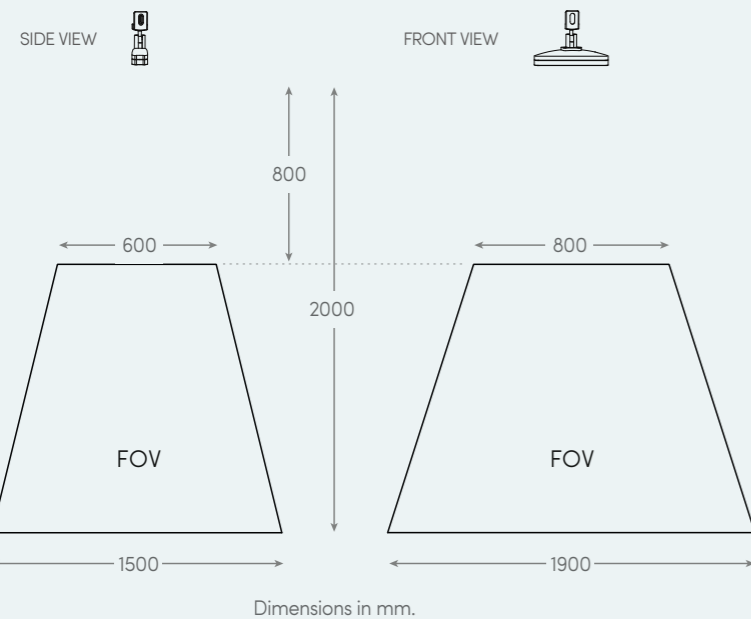
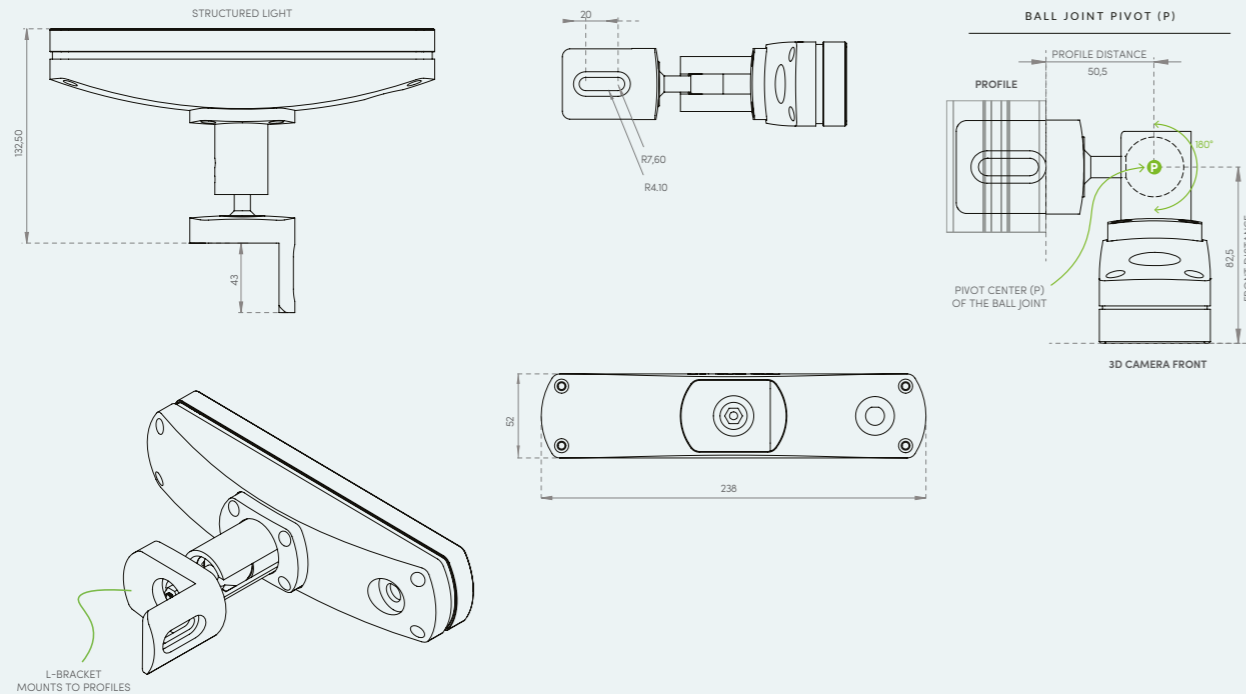

CAMERA TECHNICAL SPECIFICATIONS

3D measurement method	Structured light
3D image capturing time	300 ms
3D camera resolution (pixels)	640x480
3D camera precision (mm)*	1.0- 3.0 mm
3D camera accuracy (%)	< 1.2%
3D camera accuracy (mm)**	4 - 18 mm
Estimated picking accuracy***	1.5 - 2 x 3D camera accuracy
3D camera weight	1030 g
3D camera connection to PC	M12-8 (USB) – USB3
PC connection to robot	TCP/IP over Ethernet
Power supply	USB3 5VDC
Temperature	5°C to 40°C
Humidity	-95% @ 40°C (non-condensing)
IP rating	IP 54
Vibrations	Operating, 2 Grms, 5-500 Hz, 3 axes
Conforms to	CE, FCC

* A larger distance from the camera has lower 3D camera precision
 ** A larger FOV has lower 3D camera accuracy
 ** Average accuracy from the real production environment

CAMERA CABLE TECHNICAL SPECIFICATIONS

10 m / 20 m

High-Flex / Continuous-Flex

- Type-U (R= 67,5mm - 5.000.000 times)
- Type-S (R= 60mm - 1.000.000 times)
- 90° Tick-Tock bending (R= 60mm - 1.000.000 times)

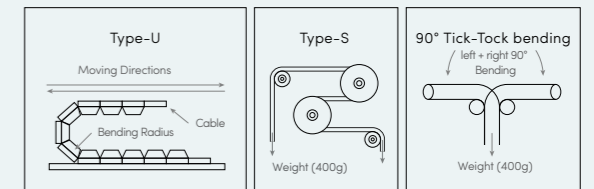

PROCESSOR

Power consumption

- While turned off: 3 W
- Booting: 35 W
- Idle: 25 W
- Heavy processing: 85 W

Technical specifications

- Processor: 6 cores (12 threads) at 3.7 Ghz
- 19 inch server: rack compatible (1U)
- Temperature: 5°C to 40°C
- Vibrations: 1Grms (HDDx1); 3 Grms (SSD x 1)
- IP rating: IP20
- Humidity: 10-85% @ 40°C
- Weight: 2.5 kg



USE PICKIT WITH THE ROBOT OF YOUR CHOICE

